

Assembly Manual for Y3024 (RP/SP)

Tool kit "TOOL-DF30" is necessary for the assembly.

1. Put the Drive Side Adapter (A) into the BB Shell (B).
Make sure the BB shell I.D. 46mm before assembly.

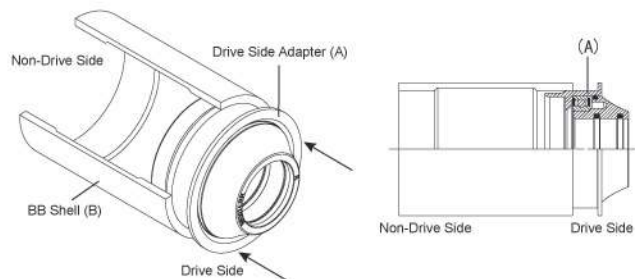

2. Penetrate the Hitch (F) with the Hex Screw (E) and tighten the Hex Screw (E) together with the Threaded Cover (C). All actions should be aligned to the pressing areas.

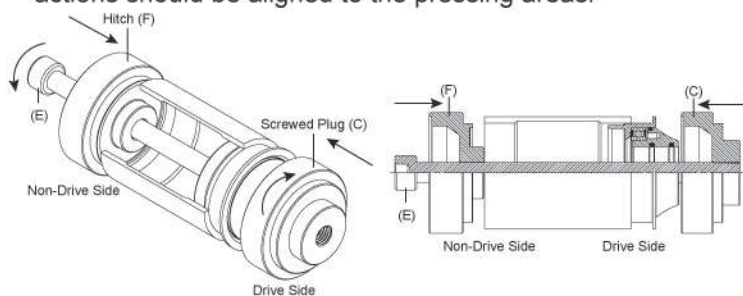

3. Tighten the Hex Screw (E) clockwise by Allen Key (G).

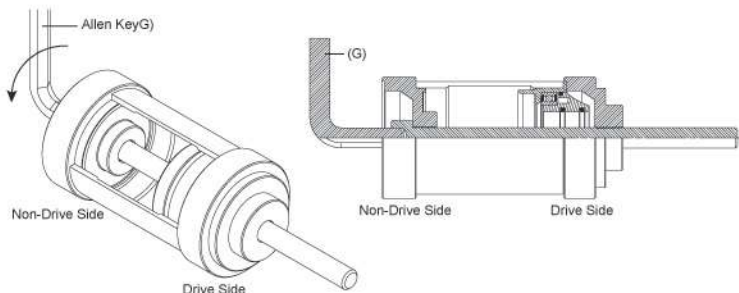

4. Remove the tool parts and have visual check to see if the Drive Side Adapter (A) was pressed to the correct position.

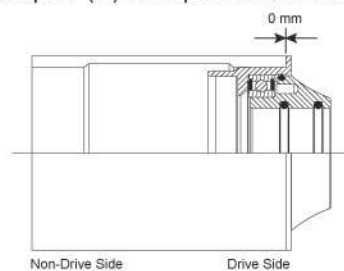

5. Put the Non-Drive Side Adapter (T) into the BB Shell (B).
Make sure the BB shell I.D. 46mm before assembly.

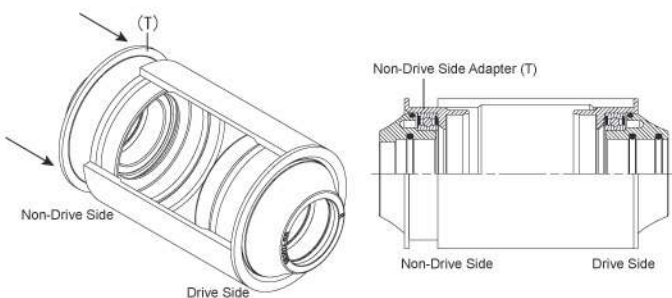

6. Penetrate the Hitch (F) with the Hex Screw (E) and tighten the Hex Screw (E) together with the Threaded Cover (C). All actions should be aligned to the pressing areas.

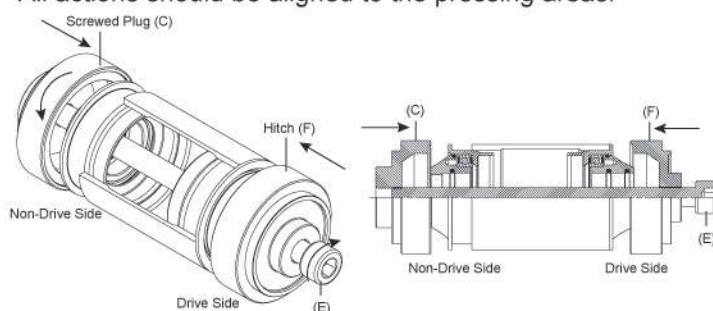

7. Tighten the Hex Screw (E) clockwise by Allen Key (G).

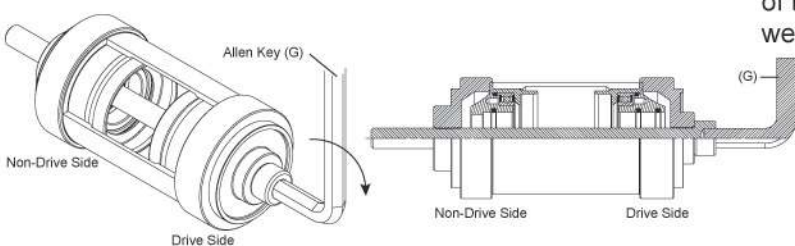

8. Remove the tool parts and have visual check to see if both of the Drive Side Adapter (A) and Non-Drive Side Adapter were pressed to the correct positions. Assembly is completed.

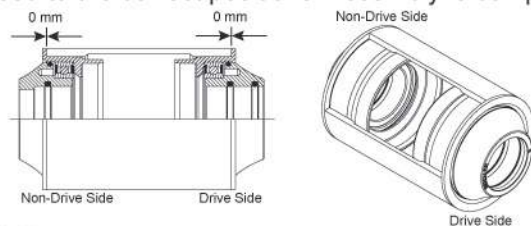

Table of Parts

A: Drive Side Adapter	K: Cylinder
B: BB Shell	M: Threaded Cover
C: Screwed Plug	N: Small Split Stopper
D: Split Ring	P: Bearing Pressing Ring
E: Hex Screw	R: Bearing Cover (24)
F: Hitch	S: Intensifying Split Stopper
G: Allen Key	T: Non-Drive Side Adapter
J: Big Split Stopper	U: Bearing Cover (22)

