



S60



S66

Wiring Diagram S60/S66線路配置圖

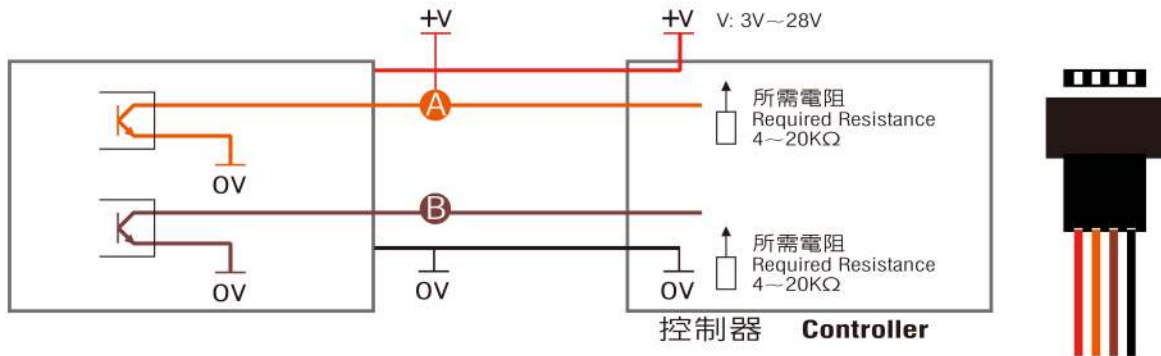

Specifications 速度感應器規格說明

Specifications 規格

- | | |
|---|---|
| • Input Voltage: DC5V~DC 24V | • 輸入電壓: DC5V~DC24V |
| • Sensory System: 2 Hall Sensors x 12 (S60)/
24 (S66) Pulses | • 感應系統: 2 Hall Sensors x 12 (S60)/
24 (S66) Pulses |
| • Red Cable: 5V | • 紅色電線: 5V |
| • Orange Cable: A Polarity | • 橙色電線: A相 |
| • Brown Cable: B Polarity | • 棕色電線: B相 |
| • Black Cable: 0V | • 黑色電線: 0V |
| • Cable Length: 800mm | • 電線長度: 800mm |

Signal Characteristics 訊號圖示

S60 (12 Pulses)/S66 (24 Pulses)

