

Assembly Manual for MP MTB Crankset

Classic . Graceful . Perfect
High Performance

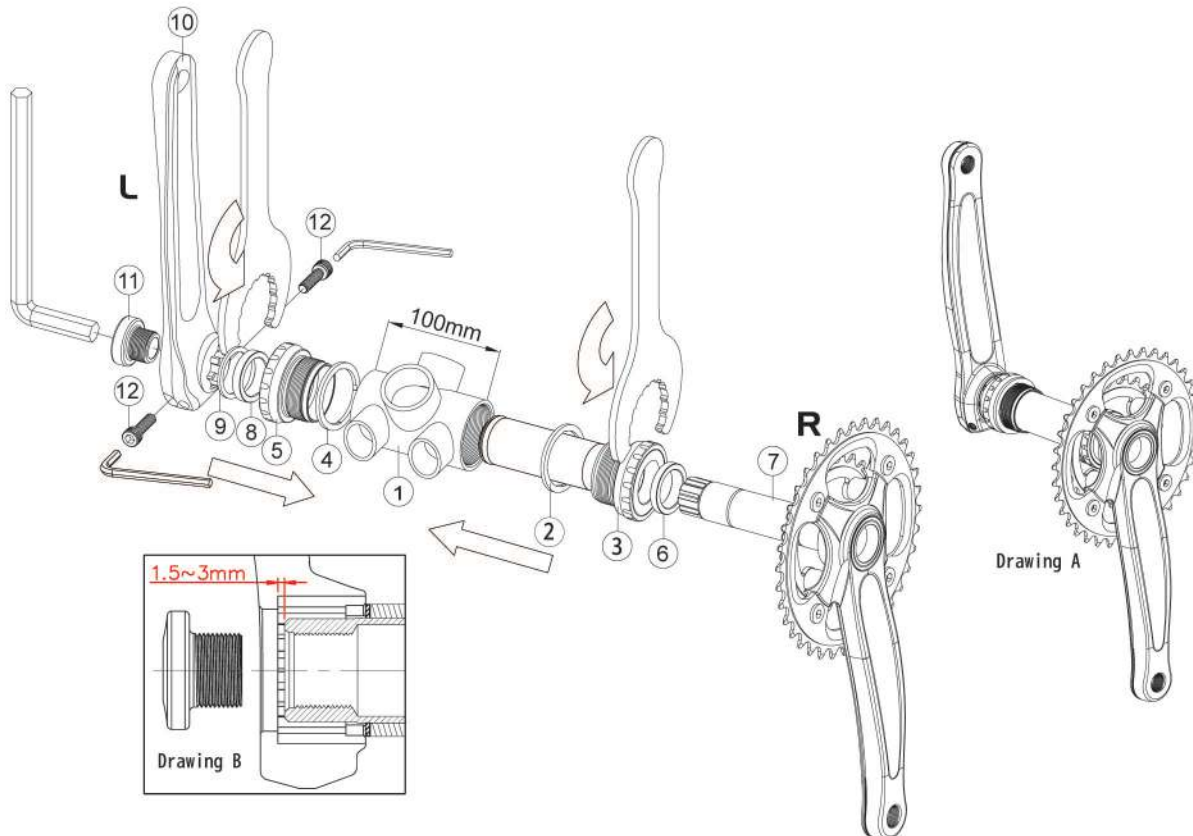

Technical instructions:

- Step 1. Apply grease to the threads inside the BB shell of the frame ①.
- Step 2. Install the drive side (R) adapter ③ with sleeve and needed spacer ② (counterclockwise thread) by special external BB cup spline tool to tighten with suggested torque 35~45Nm.
- Step 3. Install the non-drive side (L) adapter ⑤ with needed spacer ④ (clockwise thread) by special external BB cup spline tool to tighten with suggested torque 35~45Nm.
- Step 4. Insert the four-arm right crank set ⑦ smoothly into the bottom bracket set together with needed spacer ⑥.
- Step 5. Put the spacers ⑧ & ⑨ onto the axle and install the corresponding hole of left crank ⑩ to the spline end of right crank set.
- Step 6. Screw the fixing bolt ⑪ into the hole of spindle of right crank set with a 10mm Allen key and make sure the crank set is close and even to the bottom bracket set. Suggested tightening torque is 1.5Nm (Max.). (If the crank set is not close and even to the bottom bracket set, add more spacers according to the space).
- Step 7. Use 5mm Allen key to tighten separately 2 bolts ⑫ evenly and equally. (Suggested tightening torque is 12~15Nm).
- Step 8. Assembly is completed. (Drawing A)

Remark: The axle length is 177mm.

- Note :**
1. There should be proper space (around 1.5~3mm) between axle and the left crank. If the space is too small, please add 0.5mm or 1mm spacer to make it to the safe space (like Drawing B).
 2. Be sure to tighten the fixing bolt ⑪ (Step 6.) first. Then tighten the 2 bolts ⑫ (Step 7.). The Assembly order is important and can not be reverse.
 3. Follow the reverse order to proceed the disassembly. Please don't knock or hammer the four-arm right crank set. The parts might be damaged and the axle might get loose or even fall off.