

Instruction Manual for D4641A

1. Make sure the I.D. of the BB Shell (A) is $\Phi 46\text{mm}$ and width is 86.5mm. Clean the inner hole of the BB Shell and make sure there is no grease before assembly.

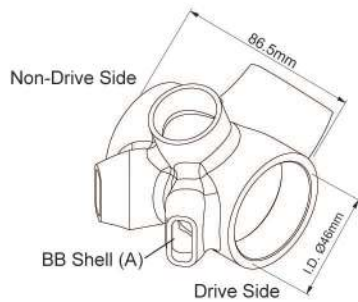

2. Firmly press the Converters (B) into the BB Shell (A) and make sure there is no gap.

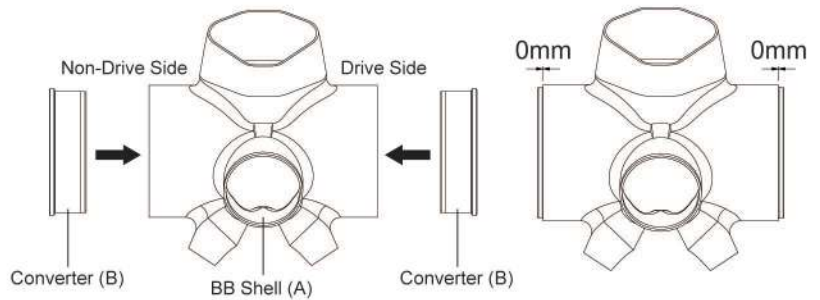

3. Firmly press the Drive Side Adapter (C) into the BB Shell (A) from the Drive Side and make sure there is no gap.

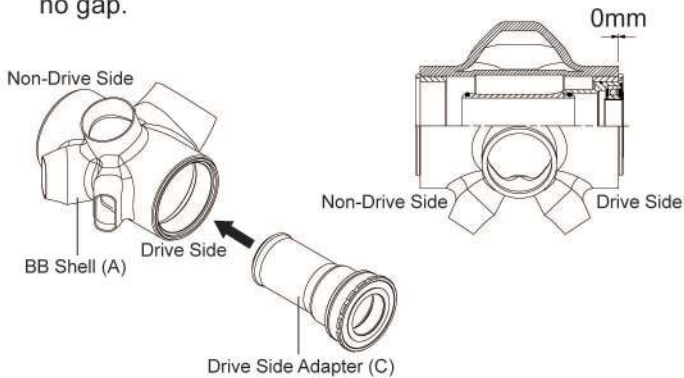

4. Firmly press the Non-Drive Side Adapter (D) into the BB Shell (A) from the Non-Drive Side and make sure there is no gap.

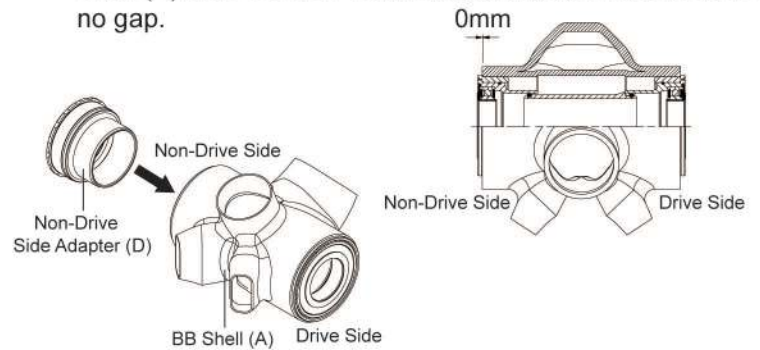

5. Assembly is completed.

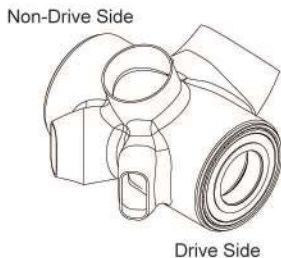

Note: After all the parts are tightened and fixed, please also periodically maintain your bike and check if any part gets loose for riding safety.