

Instruction Manual for D4234A/D4634A

1. Make sure the I.D. of the BB Shell (A) is $\Phi 42/46\text{mm}$ and width is $68/73\text{mm}$. Clean the inner hole of the BB Shell and make sure there is no grease before assembly.

D4234A : $\Phi 42\text{mm}$
D4634A : $\Phi 46\text{mm}$

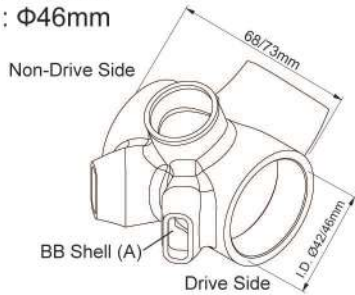

2. Counterclockwise tighten the Drive Side Adapter (B) with the Drive Side Converter (C) by hand.

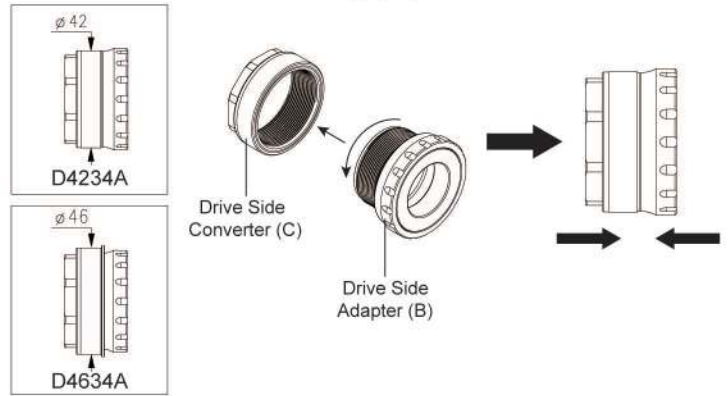

3. Counterclockwise tighten the adapter and converter with Open Wrench (38/40) and Shimano Wrench and make sure there is no gap in between. (The suggested tightening torque is 35~45 Nm.)

D4234A : 38mm
D4634A : 40mm

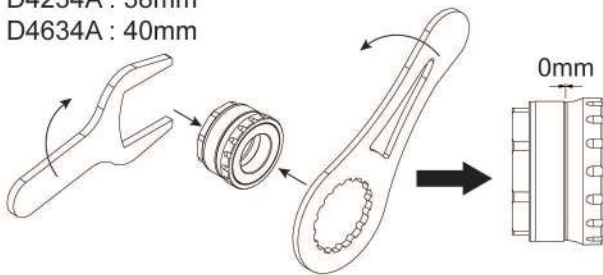

4. Follow step two and three to clockwise tighten the Non-Drive Side Adapter (D) and Non-Drive Side Converter (E). (The suggested tightening torque is 35~45 Nm.)

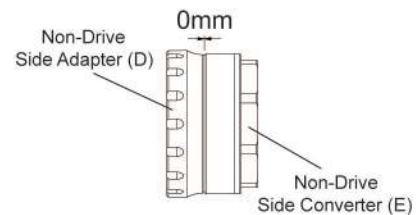

5. Firmly press the Sleeve (F) into the Drive Side Adapter (B).

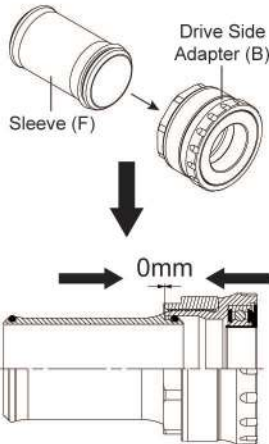

6. Press the Drive Side Adapter (B) into the BB Shell (A) from the Drive Side and make sure the Drive Side Adapter (B) is close to the end surface of the BB Shell (A) without gap.

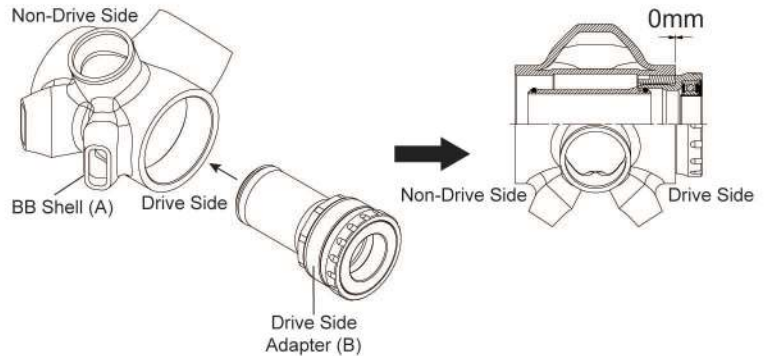

7. Press the Non-Drive Side Adapter (D) into the BB Shell (A) from the Non-Drive Side and make sure the Non-Drive Side Adapter (D) is close to the end surface of the BB Shell (A) without gap.

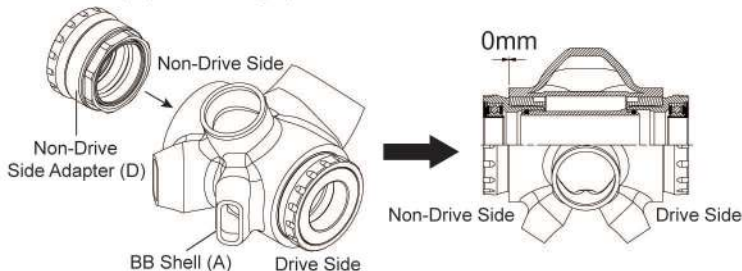

8. Assembly is completed.

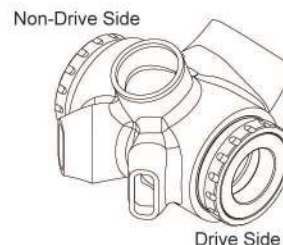

Note: After all the parts are tightened and fixed, please also periodically maintain your bike and check if any part gets loose for riding safety.